

**2U half-size compact mainframe with 2 slots**

- Maximum number of modules: 2
- Interface: USB, GPIB, LAN, RS232
- Handler interface: 4 channels
- Digital I/O: 8 bits



**Micro-current/ultra-high resistance meter modules for 4000**

- Current measurement range: 10 fA to 3.2 mA
- High-speed current measurement at 1.5 ms by integration method
- Voltage source: ±200 V (40051/40052)  
+300 V, -100 V (40053/40054)  
+2000 V, -200 V (40057)
- Contact check: 0 to 100 pF with resolution of 0.1 pF
- Handler interface: INDEX, EOM, HI, GO, LO, NC

**GPIB    USB    LAN    RS232**

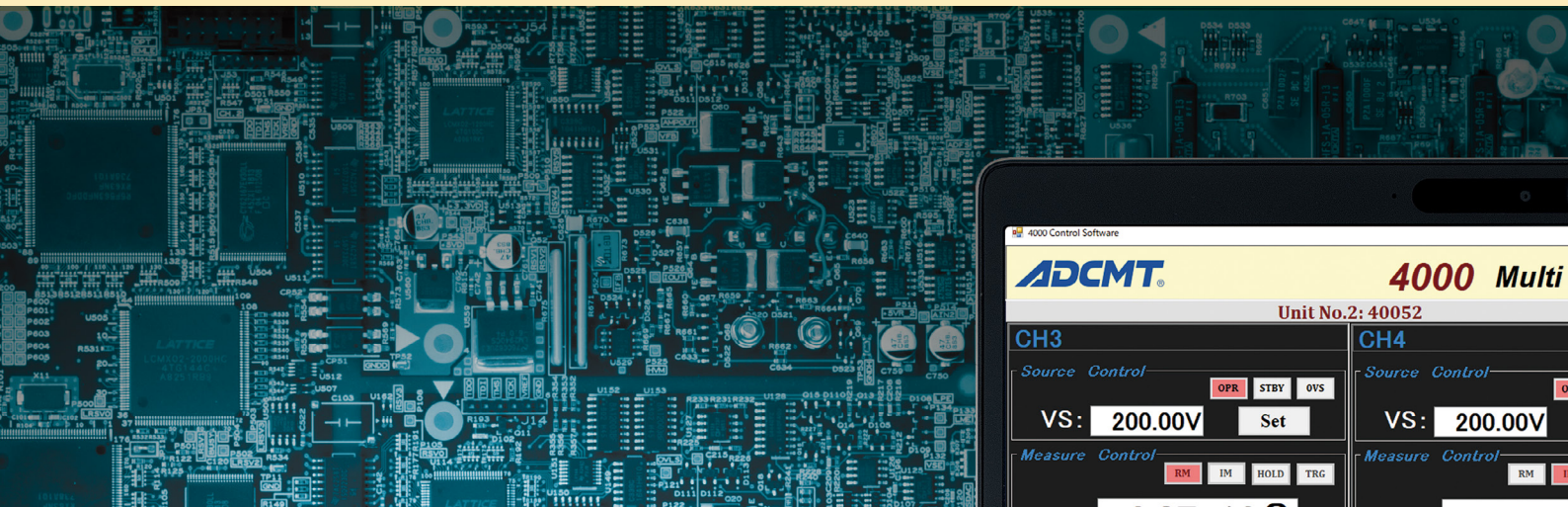

## 4000 2 Slot Modular Instrument

The 4000 is a 2-slot modular instrument of 2U half-size mainframe to which 2 units of 0.7U half-size modules can be installed.

It is equipped with various interfaces; USB, GPIB, LAN and RS232, making it possible to build inspection systems for R&D or production lines of electronics components by connecting to a personal computer or programmable controller.

In addition, the 4-channel handler interface allows you timing control with automatic machines, and device selection according to measurement and judgment results by the modules.

In inspection lines, you can easily perform system setup or maintenance of modules that are mounted on system racks without removal such as module replacement, operation check via USB on the front panel.

Moreover, by using the digital I/O of 8 bits having a 5 V/200 mA power supply, easy relay control and signal generation are available.

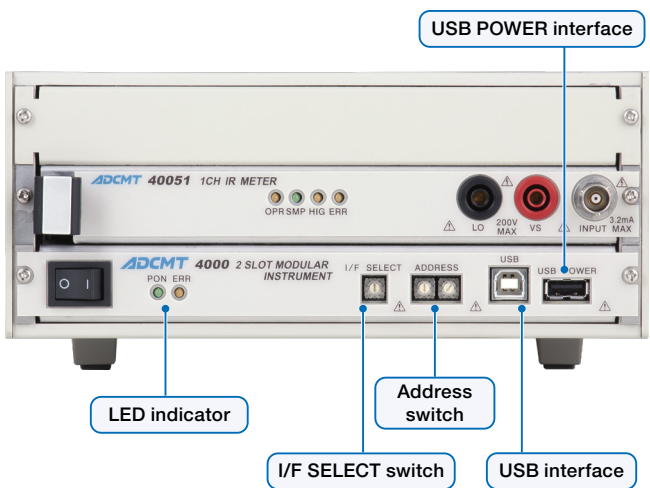

Front Panel

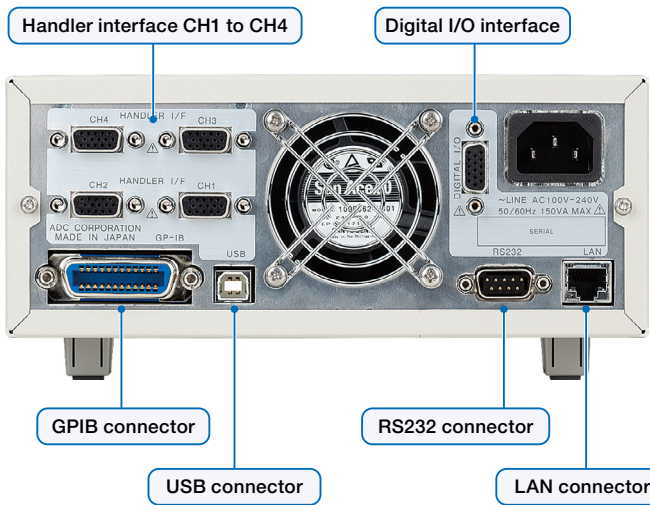

Rear Panel

## 40051/40052/40053/40054/40057 IR Meter Units

The 40051, 40052, 40053, 40054 and 40057 IR meter units are to be mounted into the 2-slots modular instrument 4000.

The 1-channel 40051, 40053 and 40057 and 2-channel 40052 and 40054 are integration-method IR meters, suitable for current measurement of high-capacity samples such as capacitors.

The current measurement range is from 10 fA to 3.2 mA, and the voltage source range is up to  $\pm 200$  V/3.2 mA for the 40051 and 40052, up to +300 V or -100 V/3.2A for the 40053 and 40054, or up to +2000 V/0.8 mA or  $\pm 200$  V/3.2 mA for the 40057. The resistance measurement range is between  $312 \Omega$  to  $3 \times 10^{17} \Omega$ .

In addition, it has a contact check function (C.CHK) by capacity (C) measurement to judge the contact status of high-resistance samples.

Moreover, the handler interface signals to be controlled from automatic machines in production lines are directly output to the rear connectors on the 4000.

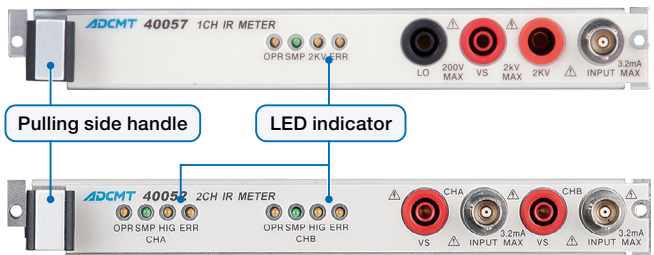

### Handler interface timing and measurement time under the conditions of DC measurement mode by external trigger

#### [Handler Interface Timing]

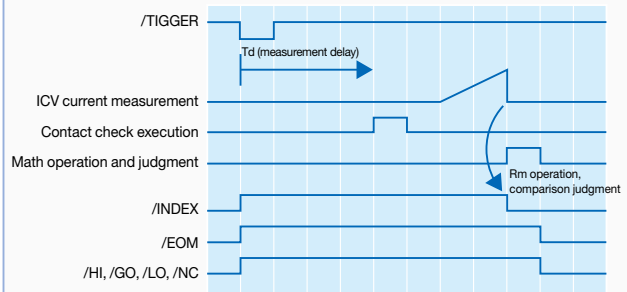

#### [Measurement time]

INDEX and EOM times in DC mode ( $T_d=0.05$  ms)

Measurement time	Typical value	$T_i=1$ ms
INDEX time (From trigger input to falling edge of /INDEX)	integration time ( $T_i$ )+ $\alpha$ ms	1.5 ms
Contact check ON	+1.5 ms	3.0 ms
EOM time (From trigger input to falling edge of /EOM)	/INDEX + 0.25 ms	1.75 ms
Resistance measurement	+0.06 ms	1.81 ms
Comparison judgment	+0.05 ms	1.86 ms
	$T_i$	$\alpha$
	1/2/5 ms	0.5/0.6/0.7
	0.5/1 PLC	1.6/1.6
	100 ms	12
	200 ms	22

INDEX and EOM times in fixed sweep mode: DC mode + 0.1 ms + Hold time (Ht)

## 2 Slot Modular Instrument 4000 Specifications

### Indicators (LEDs)

PON: Power ON

ERR: Error (Fan stopped, self-test error)

### Interface Specifications:

USB interface: USB 2.0 Full-Speed

(Front/Rear) Connector: Type B

USB POWER: Power: +5 V/1 A max

(Front) Connector: Type A

GPIO interface: Compliant to IEEE-488.1-1978

(Rear) Interface functions: SH1, AH1, T6, L4, SR1, RL1, PP0, DC1, DT1, C0, E2

Connector: Amphenol 24-pin

LAN interface: Compliant to IEEE802.3 (10BASE-T, 100BASE-TX)

(Rear) Connector: RJ-45

RS232 interface: Standard: RS232 (EIA232)

Baudrate: Up to 19200

Connector: D-Sub 9 pin

Handler interface: Input: /TRIGGER, INTERLOCK

(Rear, 4 channels) Output: /INDEX, /EOM, /COMPLETE, /HI, /GO, /LO,

/NO.CONTACT, /VS LIMIT, /ALARM

Input level: Hi; +4 to +30 V, Lo; 0 to +0.8 V

Output level: Hi; 30 V max, Lo; 0.8V max, sink; 50 mA max

Connector: D-Sub 15 pin

Digital I/O: Input/Output: 8 bits

(Rear) Input level: Hi; +4 to +30 V, Lo; 0 to +0.8 V

Output level: Hi; 30 V max, Lo; 0.8 V max, sink; 50 mA max

Power supply: +5 V/200 mA

Connector: D-Sub 15 pin

### General Specifications

Operation environment: Temperature; 0 °C to +50 °C

Relative humidity; 85 % or less with no condensation

Storage environment: Temperature; -25 °C to +70 °C

Relative humidity; 85 % or less with no condensation

Power supply: 100 VAC to 240 VAC

Power frequency: 50 Hz/60 Hz

Power consumption Mainframe with units: 150 VA or less (depending on the units)

Mainframe only (without unit): 35 VA or less

Dimensions: Approx. 212 (W) × 88 (H) × 400 (D) mm (not including feet)

Mass: 3.3 kg or less (not including units and feet)

#### Supplied accessories

Model	Quantity	Name
A01402	1	Power supply cable

#### Optional accessories

Model	Name
A02263	JIS standard, rack mount set (single)
A02264	JIS standard, rack mount set (twin)
A02463	EIA standard, rack mount set (single)
A02464	EIA standard, rack mount set (twin)
A02039	Panel mount set (single)
A02040	Panel mount set (twin)

## IR Meter Unit 40051/40052/40053/40054/40057 Specifications

All accuracy specifications are guaranteed for one year at a temperature of 23±5 °C and a relative humidity not exceeding 70 %.

### Measurement Functions

#### 1. DC current measurement

Integration time: 200 ms

Range	Maximum display	Resolution	Accuracy ±(% of reading + digits)		Temperature coefficient*1 ±(ppm of reading + digits)/°C
			At 23 °C±5 °C, for one year	Within ±3 °C for 24 hrs after INTCAL	
300 pA	319.999 pA	1 fA	0.65 + 120	0.4 + 100	600 + 15
3 nA	3.19999 nA	10 fA	0.65 + 35	0.4 + 35	600 + 2
30 nA	31.9999 nA	100 fA	0.5 + 25	0.3 + 25	600 + 1
300 nA	319.999 nA	1 pA	0.5 + 25	0.3 + 25	600 + 0.5
3 μA	3.19999 μA	10 pA	0.5 + 25	0.3 + 25	600 + 1
30 μA	31.9999 μA	100 pA	0.5 + 25	0.3 + 25	600 + 0.5
300 μA	319.999 μA	1 nA	0.5 + 21	0.3 + 21	600 + 0.5
3 mA	3.19999 mA	10 nA	0.5 + 22	0.35 + 22	600 + 0.5

Input voltage drop:

±1.5 mV + (50 Ω × measurement current) or less at input resistance 50 Ω

±1.5 mV + (1.1 kΩ × measurement current) or less and ±0.6 V or less at input resistance 1 kΩ

Input bias current: 100 fA or less

Settling time: Same time as the integration time (until the specified accuracies are satisfied.)

Maximum allowable input current: 3.2 mA

NMRR: 60 dB or more (at 50 Hz/60 Hz ±0.08 %)

\*1: At temperature of 0 to 50 °C and relative humidity of 70 % or less

±50 fA/°C is added to the digits item between +40 °C and +50 °C.

#### 2. Resistance value display (RM operation)

(Resistance value obtained by "voltage source value/current measurement value". Values in [ ] are at input resistance 1 kΩ.)

Voltage source	Current measurement	Resistance measurement range
1 V to 2000 V	10 fA to 3.2 mA	312 Ω to 3 × 10 <sup>17</sup> Ω

Measurement accuracy:

±((rdg item of current measurement range + setting item of voltage source range)

+ (digits item of voltage source range × resolution × 100/source voltage value)

+ (resistance reading value × digits item of current measurement range ×

resolution × 100/source voltage value)% + 50 Ω [1.1 kΩ]

Temperature coefficient:

±((rdg item of current measurement range + setting item of voltage source range)

+ (digits item of voltage source range × resolution × 100/source voltage value)

+ (resistance reading value × digits item of current measurement range ×

resolution × 100/source voltage value)%/°C + 5 Ω/°C [6 Ω/°C]

Maximum display: 1 to 5 digits (1 to 9.9999)

Example of integration time 200 ms, input voltage ±100 V and input resistance 50 Ω

Current range	Measurement range [Ω]	Accuracy	
		At 23 °C ±5 °C, for one year	Within ±3 °C for 24 hrs after INTCAL
300 pA	3.12×10 <sup>11</sup> to 1×10 <sup>16</sup>	0.68+0.05+1.2×10 <sup>-15</sup> Rm+50 Ω	0.43+0.05+1×10 <sup>-15</sup> Rm+50 Ω
3 nA	3.12×10 <sup>10</sup> to 1×10 <sup>15</sup>	0.68+0.05+3.5×10 <sup>-15</sup> Rm+50 Ω	0.43+0.05+3.5×10 <sup>-15</sup> Rm+50 Ω
30 nA	3.12×10 <sup>9</sup> to 1×10 <sup>14</sup>	0.53+0.05+2.5×10 <sup>-12</sup> Rm+50 Ω	0.33+0.05+2.5×10 <sup>-12</sup> Rm+50 Ω
300 nA	3.12×10 <sup>8</sup> to 1×10 <sup>13</sup>	0.53+0.05+2.5×10 <sup>-11</sup> Rm+50 Ω	0.33+0.05+2.5×10 <sup>-11</sup> Rm+50 Ω
3 μA	3.12×10 <sup>7</sup> to 1×10 <sup>12</sup>	0.53+0.05+2.5×10 <sup>-10</sup> Rm+50 Ω	0.33+0.05+2.5×10 <sup>-10</sup> Rm+50 Ω
30 μA	3.12×10 <sup>6</sup> to 1×10 <sup>11</sup>	0.53+0.05+2.5×10 <sup>-9</sup> Rm+50 Ω	0.33+0.05+2.5×10 <sup>-9</sup> Rm+50 Ω
300 μA	3.12×10 <sup>5</sup> to 1×10 <sup>10</sup>	0.53+0.05+2.1×10 <sup>-8</sup> Rm+50 Ω	0.33+0.05+2.1×10 <sup>-8</sup> Rm+50 Ω
3 mA	3.12×10 <sup>4</sup> to 1×10 <sup>9</sup>	0.53+0.05+2.2×10 <sup>-7</sup> Rm+50 Ω	0.38+0.05+2.2×10 <sup>-7</sup> Rm+50 Ω

Rm: resistance reading value

#### 3. Additional errors in DC current measurement

Additional error for each integration time other than 200 ms. For each integration time (IT), the following accuracies are added to the accuracies of the integration time of 200 ms

±(% of reading + digits)

Integration time (IT)	Accuracy									
	1 ms, 2 ms		5 ms		0.5 PLC		1 PLC		100 ms	
Range	rdg	digits	rdg	digits	rdg	digits	rdg	digits	rdg	digits
300 pA	0	30	0	30	0	30	0	30	0	30
3 nA	0	265	0	265	0	165	0	65	0	15
30 nA	0.15	125	0.15	55	0.15	25	0.15	5	0	5
300 nA	0.15	25	0	55	0	25	0	5	0	0
3 μA	0	25	0	25	0	5	0	0	0	0
30 μA	0	5	0	55	0	25	0	0	0	0
300 μA	0	25	0	25	0	5	0	0	0	0
3 mA	0	15	0	5	0	5	0	2	0	0

PLC: Power Line Cycle (50 Hz: 20 ms, 60 Hz: 16.67 ms)

Integration time by ICV method (Ti) against setting integration time (IT)

Range	Setting integration time (IT)					
	1 ms	2 ms	5 ms	0.5 PLC	1 PLC	100 ms
300 pA	100 ms					200 ms
3 nA	5 ms		5 ms	0.5 PLC	1 PLC	100 ms
30 nA to 30 μA	1 ms	2 ms	5 ms	0.5 PLC	1 PLC	100 ms
300 μA	1 ms	2 ms	5 ms	0.5 PLC	1 PLC	1 PLC×4
3 mA	1 ms	2 ms	1 ms×2	2 ms×2	2 ms×4	2 ms×20

The expressions such as "2 ms × 2" indicate that measurement is performed by using the average of two measurements with integration time of 2 ms.

### Source Functions

#### ● Voltage source

Range	Maximum display	Resolution	Accuracy ±(% of setting + digits)	Temperature coefficient ±(ppm of setting + digits)/°C
30 V	±32.000 V	1 mV	0.03 + 6	20 + 0.5
200 V <sup>2</sup>	±200.00 V	10 mV	0.03 + 5	20 + 0.5
300 V <sup>2</sup>	+300.00 V			
2000 V <sup>2</sup>	+2000.0 V	100 mV	0.2 + 12	150 + 1

Settling time (until the final value ±0.1 % is reached): 3.5 ms or less (200 V), 4.1 ms (300 V), 1 s or less (2000 V)

Maximum allowable input voltage: ±200 V peak (40051/40052/40057 VS terminal)

+300 V -100 V peak (40053/40054), +2000 V peak (40057 2 kV terminal)

Maximum capacitance load: 30 V, 200 V, 300 V range: 1000 μF, 2000 V range: 100/ Vs [μF]

1000 V: 0.1 μF, 2000 V: 0.05 μF

\*2: The 200 V range is for the 40051/40052/40057 only, the 300 V range is for the 40053/40054 only, and the 2000 V range is for the 40057 only. The output range is from +50 V to +2000 V.

●Output noise

Peak to peak values under the following load conditions

Range	Load resistance	DC to 100 Hz	DC to 10 kHz
30 V	No load or maximum load	1 mV	3 mV
200 V <sup>*2</sup>		3 mV	10 mV
300 V <sup>*2</sup>			
2000 V <sup>*2</sup>			

\*2: The 200 V range is for the 40051/40052/40057 only, the 300 V range is for the 40053/40054 only, and the 2000 V range is for the 40057 only.

●Current limit

The difference between +IL and -IL must be 0.06 mA or higher.

Range	Maximum display	Resolution	Accuracy ±(% of setting + digits)	Temperature coefficient ±(ppm of setting + digits) / °C	Setting range
3 mA	3.200 mA	1 µA	0.1 + 23	30 + 0.6	0.03 mA to 3.200 mA

2KV terminal: 0.8 mA to 1.2 mA (fixed)

Setting Time

Source delay time (Tds), Period (measurement cycle) (Tp), Measurement delay time (Td):

Setting time	Resolution	Setting accuracy
0.030 ms to 60.000 ms (Source delay) 0.100 ms to 60.000 ms (Period) 0.050 ms to 60.000 ms (Measurement delay)	1 µs	±(0.1 % + 10 µs)
60.01 ms to 600.00 ms	10 µs	
600.1 ms to 6000.0 ms	100 µs	
6001 ms to 59998 ms	1 ms	

Hold time (Th):

Setting time	Resolution	Setting accuracy
0 ms to 6000.0 ms	0.1 ms	±(2 % + 2 ms)
6001 ms to 60000 ms	1 ms	

Source and Measurement Functions

Source mode: DC mode, Sweep mode  
 Sweep type: Fixed level sweep, linear sweep  
 Sweep repeat count: 1 to 1,000  
 Maximum number of sweep steps: 10,000 steps/channel  
 Measurement data buffer memory: 10,000 data/channel

Comparison operation: HI, GO, LO

Contact check function:  
 Measurement range: 0 to 100 pF  
 Measurement frequency: 500 kHz, 315 kHz  
 Resolution: 0.1 pF/500 kHz, 0.2 pF/315 kHz  
 Open Cal: 0 pF to 90 pF  
 Maximum cable length: TRIAX cable 3 m

Measurement terminal: INPUT TRIAXIAL connector  
 LO Safety socket (40051/40053/40057)  
 Voltage output terminal: VS Safety socket  
 2KV High-voltage safety socket (40057)

Maximum input voltage/current between terminals:

	Internal shield	VS	LO	Chassis	2KV <sup>*6</sup>
INPUT	3.2 mA	3.2 mA	3.2 mA	3.2 mA	+2000 V
Internal shield		<sup>*5</sup>	short <sup>*3</sup>	<sup>*4</sup>	+2000 V
VS			<sup>*5</sup>	<sup>*4</sup>	+2000 V
LO				<sup>*4</sup>	+2000 V
Chassis					+2000 V

\*3: The internal shield is connected to the LO terminal.

\*4: The chassis is connected to the LO or the VS terminal depending on the relay.

Apply <sup>\*5</sup> for the terminal where no connection is made. The 40057 is connected to the LO terminal.

\*5: 200 V (40051/40052/40057), +300 V -100 V (40053/40054)

\*6: The 2KV terminal is for the 40057 only.

Indicators (LEDs)

OPR Operate (output ON)  
 SMP Sampling indicator  
 HIG VS-GND connecting status  
 ERR Error (VS LIMIT, self test error, unit error)  
 2KV Voltage output from 2KV terminal

General Specifications

Operation environment: Temperature; 0 °C to +50 °C  
 Relative humidity; 85 % or less with no condensation  
 Storage environment: Temperature; -25 °C to +70 °C  
 Relative humidity; 85 % or less with no condensation  
 Warm-up time 60 minutes or longer  
 (until the specified accuracies are satisfied.)  
 Power consumption 40051/40053: 7.5 VA or less,  
 40052/40054: 15 VA or less, 40057: 13 VA or less  
 Dimensions: Approx. 207 (W) × 26 (H) × 365 (D) mm  
 Mass: 40051/40053/40057: 0.8 kg or less,  
 40052/40054: 1.0 kg or less

Optional accessories

Model	Description
A01009	TRIAX- TRIAX cable
A01239	High-voltage TRIAX- TRIAX cable
A01010	TRIAX-alligator cable
A01011	TRIAX- BNC cable
A04201	TRIAX-J- TRIAX J adapter
A04202	TRIAX-J - BNC-P 1 adapter (inside-outside)
A04203	TRIAX-J - BNC-P 2 adapter (outside-outside)
A04204	BNC-J - TRIAX-P 1 adapter (outside-inside)
A04205	BNC-J - TRIAX-P 2 adapter ((outside-(inside+outside))
A04206	TRIAX-J - BNC-P 3 adapter ((inside+outside)-outside)
A04207	BNC-J - M-P
A04208	TRIAX-J receptacle
CC010010-150	High-voltage safety cable, red, 1.5 m

• Please read through the operation manual carefully before using the products.  
 • All specifications are subject to change without notice.



ADC CORPORATION

E-mail : kcc@adcmt.com URL : http://www.adcmt.com

Head Office (R&D Center)

77-1, Miyako Namegawa-machi, Hiki-gun,  
 Saitama 355-0812, Japan  
 Phone: +81-493-56-4433 Fax: +81-493-57-1092

East Branch (Sales Dept.)

Okabe-building, 3-515, Onari-cho, Omiya-ku, Saitama-shi,  
 Saitama 330-0852, Japan  
 Phone: +81-48-651-4433 Fax: +81-48-651-4432